



HISTORIC SEATS

THE WORLD'S FINEST AUTOMOTIVE SEATS



COBRA®
●●●

At **Cobra** the love of vehicles runs in our

For three generations we have been creating some of the world's finest automotive seating and while we have built a reputation for supplying some of the world's safest, lightest and most ergonomically efficient car seats for modern racing cars, our passion to design and manufacture seats for classic cars has grown from generation to generation.

The story began in the 1960s when Mark Dunsford's Grandfather built a reputation for unsurpassed craftsmanship while working as the Master Trimmer on the legendary AC Cobra sports cars at their factory in Thames Ditton. He worked on cars that were driven by legends such as Stirling Moss and Steve McQueen. His son inherited both a love of motorsport and a keen eye for detail and began to develop a range of seats for some of the classic sports cars of the time.





classic veins.



In the last 40 years some of those traditional skills have remained unchanged - the ability to craft leather and the attention to fine detail to ensure that stitching is both functional and aesthetically pleasing. However, automotive technology has evolved enormously in those 40 years and Cobra has embraced the latest space and aeronautical technology to develop seats which lead the market in terms of materials, safety and ergonomics.

The result of 40 years of continuous development, Cobra offers an unsurpassed range of historic seats: The Cobra range embraces seats which will fit into the vast majority of cars past and present, from the tiny and spartan to the grandest and most luxurious.

This brochure provides an introduction to the range of Cobra historic seats. The choice is truly impressive so when you ask the question

- Will it fit into my car?
- Will it provide a comfortable driving position?
- Will it aesthetically enhance the appearance of my car?

You will find a seat in the Cobra range which comfortably ticks all three boxes.

Stuttgart

A classic recliner in every sense of the word, structured around a modern day, fully tested and approved frame that both reclines and tilts forward for easy access to the rear of the vehicle. The Stuttgart is reminiscent of early Classic 911s with period styling features and original upholstery but would look at home in almost any classic sports car.

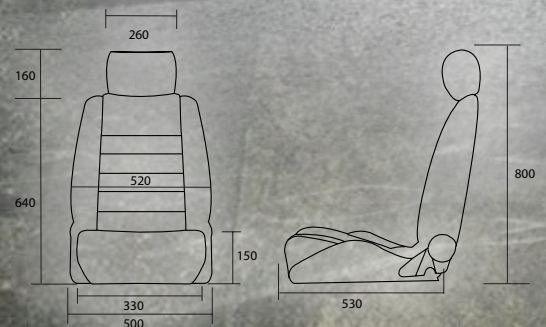



TwoPlusTwo

The TwoPlusTwo is a more faithful representation of the classic 911 sports seat and features the same upholstery and trim details as the Stuttgart but remains true to the original seat for styling, comfort and manual recline mechanism. Made in the same UK factory to the same quality standards as all Cobra Seats, the TwoPlusTwo remains committed to its heritage.

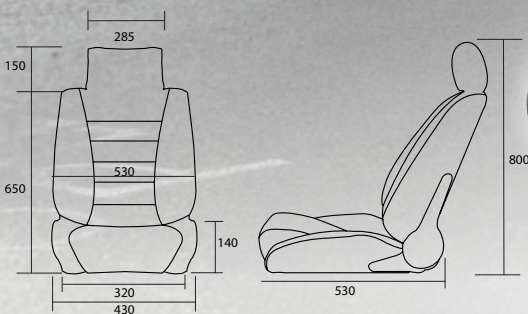

Cobra Classic



Almost 50 years in continuous production and still going strong!

One of the first seats ever designed by Cobra in the 1960s, the Classic was one of the very first aftermarket seats ever marketed in the UK. Since those far off days, the technology may have changed and materials may have improved but the design of the seat remains quintessentially the same as it was when the Beatles ruled the airwaves!

The Classic is the original sports seat, providing ideal support and stripped down driving pleasure.

Its slim design means that it fits the majority of vehicles yet it provides a generous fit for the driver.

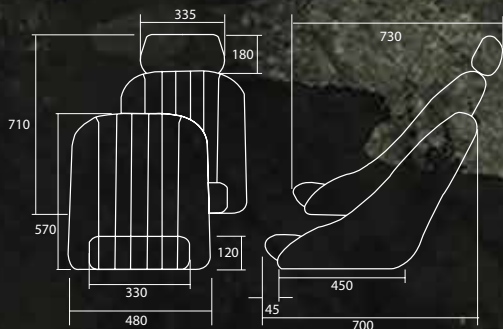



Classic GT

The Classic GT is designed for the driver that wants the style and simplicity of the Classic, but with a traditional style headrest. Period authenticity is added by a design option which features the choice of a black vinyl and cord trim.

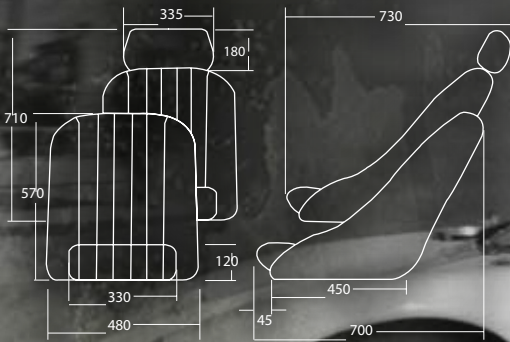

Classic CS

The CS derivative is designed with safety as well style in mind. In addition to all the Classic features, the CS has side slots to accommodate a four-point safety harness.

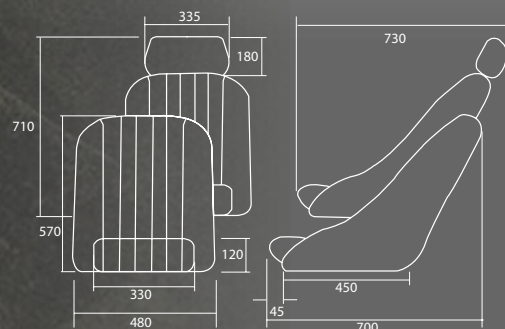

The Classic RS

A design classic that harks back to the 1970s when bucket seats first appeared in Porsche sports cars. It features a narrow backrest sculpted at the base to fit into the smallest cockpits. Cobra's design skills mean that the seat seemingly achieves the impossible - helping you to fit a generous seat with a distinctive sporty feel into a restricted space.

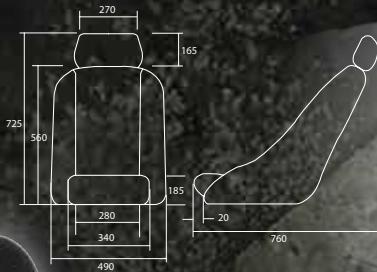



Stelvio

The Stelvio is a derivative of the Classic RS and features the diamond quilted surround which is particularly redolent of 1970s design classic the Renault Alpine.

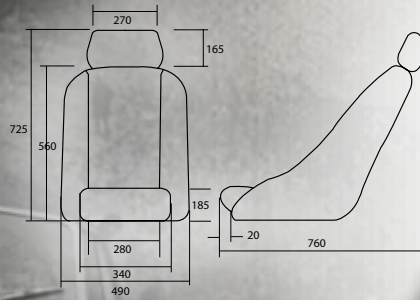

The Cobra Cub

Available with or without a headrest, the Cobra Cub has been designed to go where virtually no other seats will go!

It's the smallest, slimmest seat that Cobra has ever made. It is designed for those cars where you simply wedge yourself into the cockpit. Not in itself a sports seat, it is designed to go into cars where the transmission tunnel on one side and the driver's door on the other will provide the side support you need. Taking up minimal space between you and the car, it really puts you in touch with the road and gives you a stripped down driving experience.

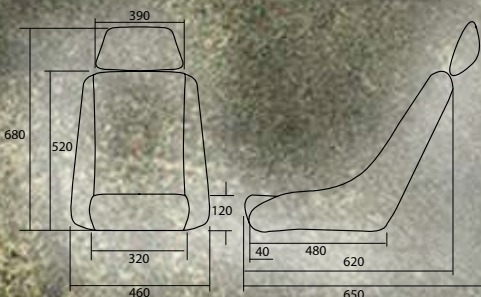

Interlagos

A natural evolution from the Classic. The Interlagos and Monte Carlo seats demonstrate how Cobra's unique understanding of the historic market allows seats to evolve to meet the needs of the enthusiast.

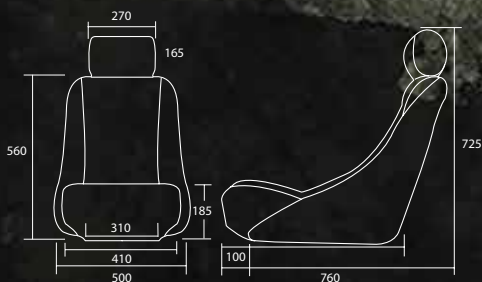

Each of the seats have been designed with a subtly tapering back to enable them to fit into smaller cockpits, but lower side supports mean that most drivers don't even realise that they are sitting in a narrower seat. These seats also feature a longer seat cushion - making them ideal for deeper cockpits.



The Classic RSR

A more sporty version of the Classic RS, inspired by the legendary Cologne motorsport era. The Classic RSR features fantastic side supports to create the closest thing to a professional sports seat of the 1970s.

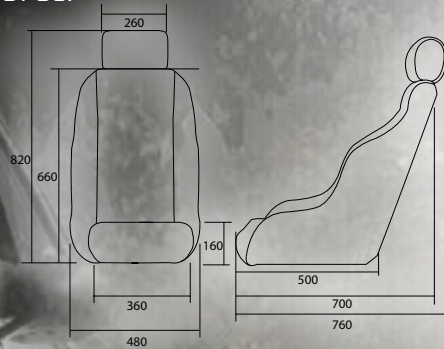

Monte Carlo

The Monte Carlo shares the design features of the Interlagos, but has a classic style headrest. The period design references are further enhanced by the use of vinyl and corduroy.

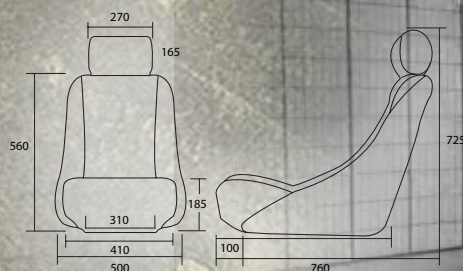

The Roadster

The Roadster range harks back to Grandfather's work with the legendary AC Cobra in the 1960s: With its flat base and curved back it carries design features that Carroll Shelby would surely recognise.

Roadster SS

The Roadster SS offers the same basic characteristics as the rest of the Roadster range, but the curve on the backrest is less pronounced and the seats taper to provide a smaller footprint than the other seats in the Roadster range.

The fact that it is narrow at the bottom enables you to fit the Roadster SS into cars with more confined space without any impact on seat width.

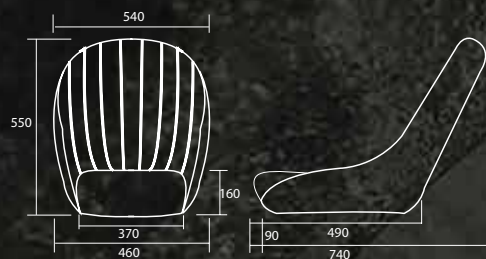

Roadster SR

A "good old fashioned GT seat" with an upright driving position and a moderate degree of side support.

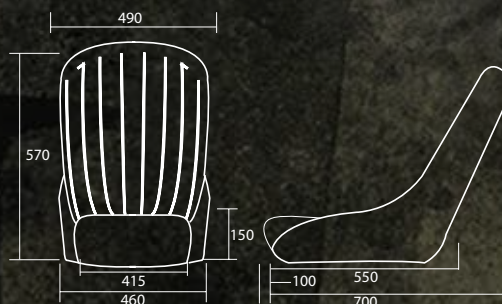



Roadster XL

The Roadster XL contains all of the design features of the Roadster SR, but offers more generous seating, while the Roadster XL+ can accommodate a larger driver still.

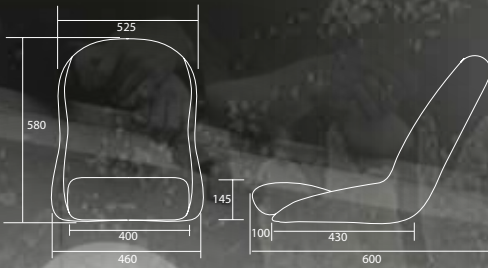

Roadster XL+

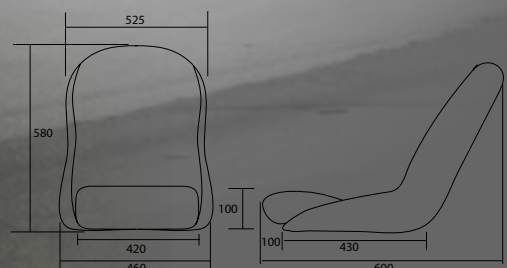

Roadster 7

Originally designed with Lotus 7 replicas in mind, the Roadster 7 is ideal for any simple lightweight two seater sports car which embodies the ideal of high performance through low weight and simplicity. The Roadster 7 meets IVA regulations and is available with or without an integral head pad and with or without slots for a four-point harness.

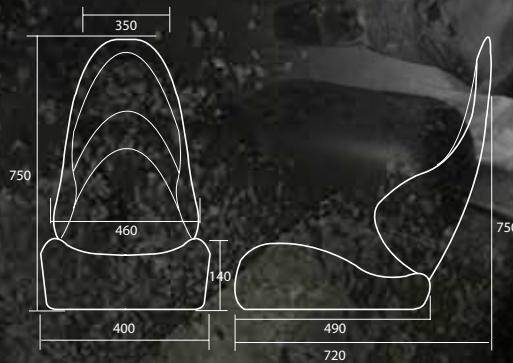

The FIA Historic

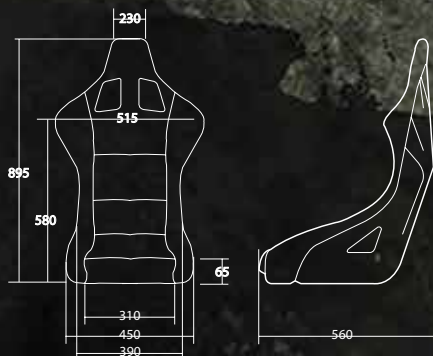

FIA homologation means the Cobra FIA Historic seat meets all competition requirements. This is a modern composite seat to provide maximum safety yet it features old school livery to combine heritage feel with the most modern materials. Designed exclusively for use in historic competition vehicles, where space is at a premium and FIA approval is mandatory, this is the narrowest FIA approved seat on the market.



Signature



The vast majority of Cobra seats are available both in standard trim or can be customised to your precise requirements.

- Our Signature service means you can specify an almost unlimited range of colours.
- Contrasting panels both in terms of colour or material.
- A vast range of materials from the finest Connolly hide through to state-of-the-art fabrics.
- Contrasting stitching again in virtually any colour of your choice.
- You can even choose to personalise your seat with logos or names.

No matter what your car, no matter what your budget, you can find a Cobra seat which will enhance the appearance of your car, increase your safety and improve your driving experience.



Technical Data

STUTTGART

- A classic recliner designed around cars of the late 60s and early 70s.
- At home in most British Italian and German sports cars.
- Styling is reserved and modest, with slimmer cushions which maximise cockpit room.
- Bolstering is minimal but supportive, providing good comfort for larger people while keeping a sporty feel.
- Authentic period styling is built on internal framework which is tested and approved to latest standards with dual recline hand wheels and a tilt forward facility.
- Available in period trims including vinyl surrounds with piping, basket weave, corduroy and hounds-tooth centres and a classic styled adjustable head restraint.

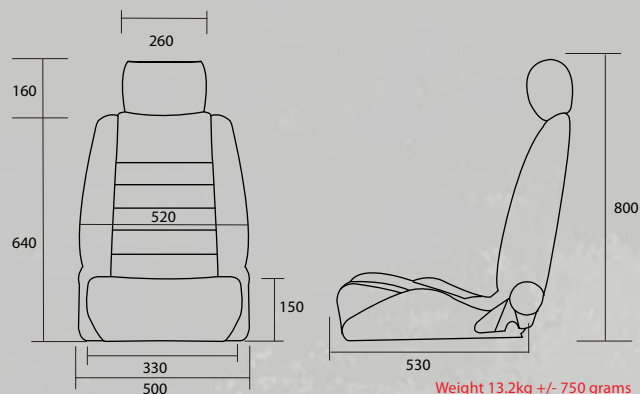

TWOPLUSTWO

- A classic recliner inspired by the Porsche cars of the late 60s and early 70s.
- Features a single side style lever mechanism – precisely what the discerning restoration enthusiast is looking for.
- Foam bolsters are more pronounced on the back and base and the centres have a more sporty profile.
- The adjustable headrest is classically styled and can be tilted as well
- Available in period trims including vinyl surrounds with piping, basket weave, corduroy and hounds-tooth centres and a classic styled adjustable head restraint.

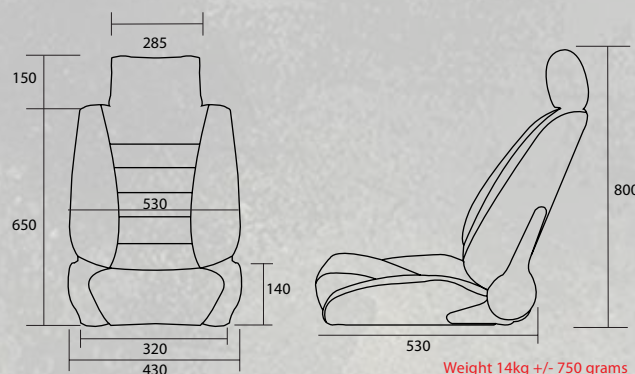

CLASSIC

- Historic fixed back competition and road seat
- Period styling with modern construction
- Tubular steel frame with base suspension diaphragm
- Optional head restraint facility
- Heavy duty standard vinyl upholstery in black or grey
- Extensive fabric, vinyl and leather Signature options

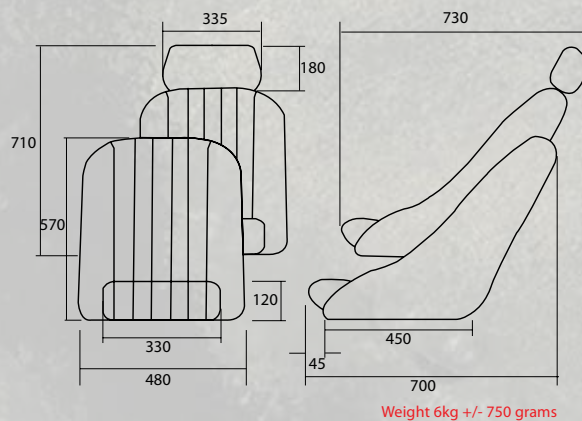

CLASSIC GT

- Historic fixed back competition and road seat
- Period styling with modern construction
- Tubular steel frame with base suspension diaphragm
- Optional head restraint facility
- Heavy duty standard vinyl upholstery in black or grey
- Extensive fabric, vinyl and leather Signature options

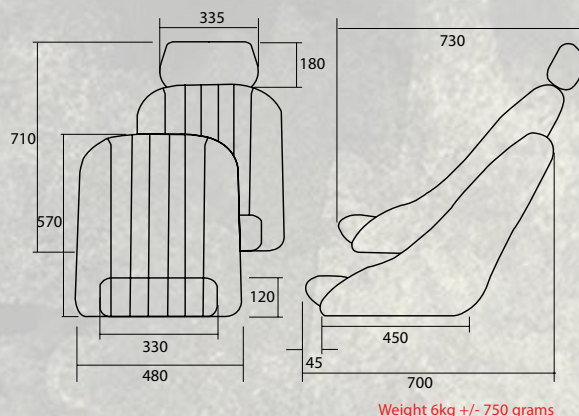

CLASSIC CS

- Historic fixed back competition and road seat
- Period styling with modern construction
- Tubular steel frame with base suspension diaphragm
- 4 point harness facility
- Standard adjustable head restraint
- Heavy duty standard vinyl upholstery in black or grey
- Extensive fabric, vinyl and leather Signature options

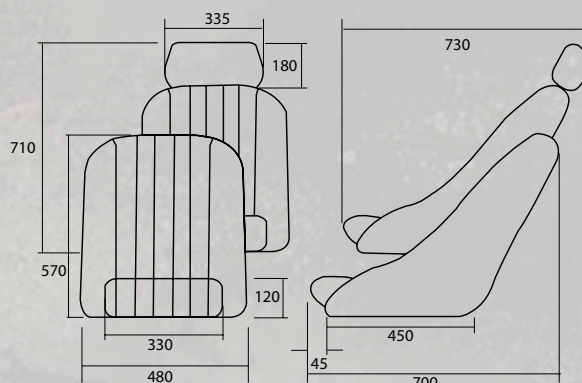

Weight 6kg +/- 750 grams

INTERLAGOS

- Historic fixed back competition and road seat
- Designed for cars with smaller cockpits (especially where clearance around the b-pillar is an issue).
- Subtly tapering back and clever ergonomics provide comfortable seating even for taller drivers
- Features a slightly more modern style of headrest
- Trimmed in vinyl with vertical flutes

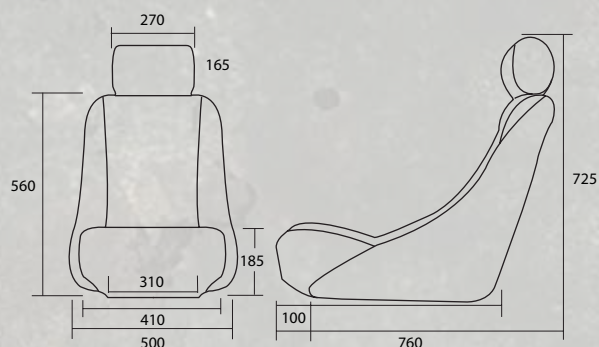

Weight 7kg +/- 750 grams

STELVIO

- Historic fixed back competition and road seat
- Quilted sides provide period authenticity and charm and a wonderful feeling of quality
- Period styling with modern construction
- Standard adjustable head restraint
- Extensive fabric, vinyl and leather Signature options.

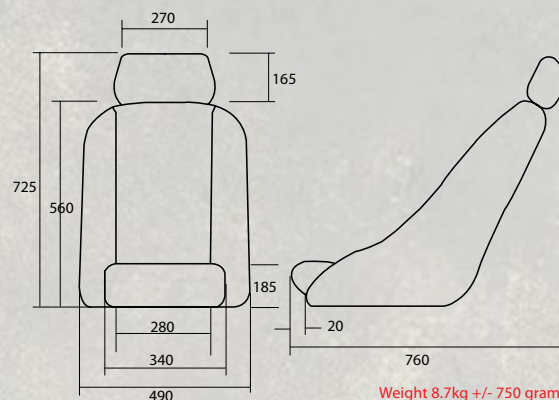

Weight 8.7kg +/- 750 grams

MONTE CARLO

- Historic fixed back competition and road seat
- Designed for cars with smaller cockpits (especially where clearance around the b-pillar is an issue).
- Subtly tapering back and clever ergonomics provide comfortable seating even for taller drivers
- Features a classic "rolled" style of headrest
- Trimmed in true classic style with basket weave or corduroy

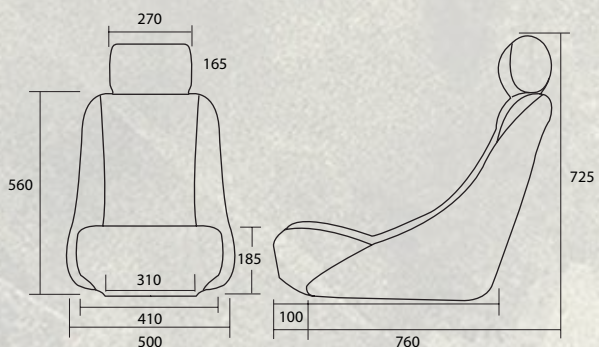

Weight 7kg +/- 750 grams

Technical Data

CLASSIC RS

- Historic fixed back competition and road seat
- Period styling with modern construction
- Tubular steel frame with base suspension diaphragm
- Standard adjustable head restraint
- Upholstered in black soft grain vinyl and traditional corded centres
- Extensive fabric, vinyl and leather Signature options

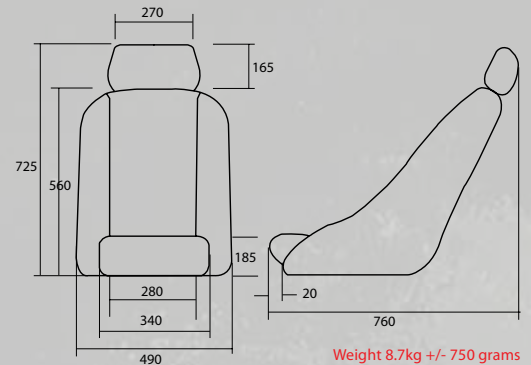

Weight 8.7kg +/- 750 grams

CLASSIC RSR

- Historic fixed back competition and road seat
- Period styling with modern construction
- Tubular steel frame with base suspension diaphragm
- Standard adjustable head restraint
- Upholstered in black soft grain vinyl and traditional corded centres
- Extensive fabric, vinyl and leather Signature options

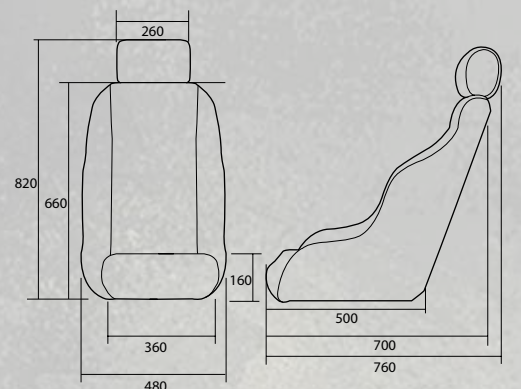

Weight 8.5kg +/- 750 grams

CUB

- Historic fixed back competition and road seat
- Period styling with modern construction
- Tubular steel frame with base suspension diaphragm
- Compact dimensions for narrow cockpit applications
- Optional head restraint facility
- Heavy duty standard vinyl upholstery in black or grey
- Extensive fabric, vinyl and leather Signature options

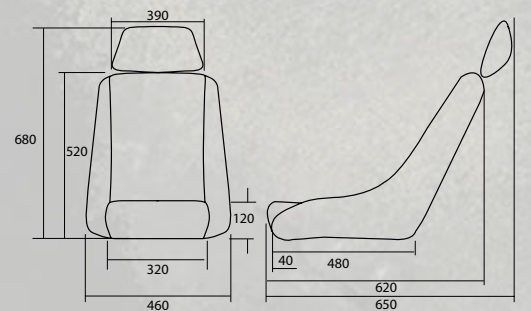

Weight 8.5kg +/- 750 grams

ROADSTER SS

- Classic/period fixed back sports seat
- Traditional styling with modern construction
- Tubular steel frame with base suspension diaphragm
- Narrow flat base for low applications
- Optional head restraint facility
- Heavy duty standard vinyl upholstery in black or grey
- Extensive fabric, vinyl and leather Signature options

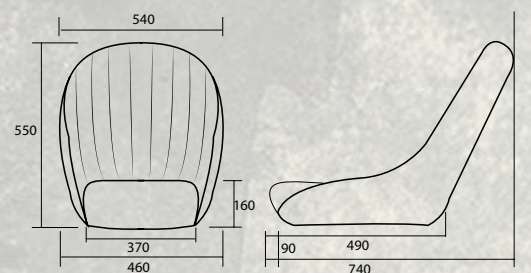

Weight 6.4kg +/- 750 grams

ROADSTER SR

- Classic/period fixed back sports seat
- Traditional styling with modern construction
- Tubular steel frame with base suspension diaphragm
- Deeper lateral hip support
- Optional head restraint facility
- Heavy duty standard vinyl upholstery in black or grey
- Extensive fabric, vinyl and leather Signature options

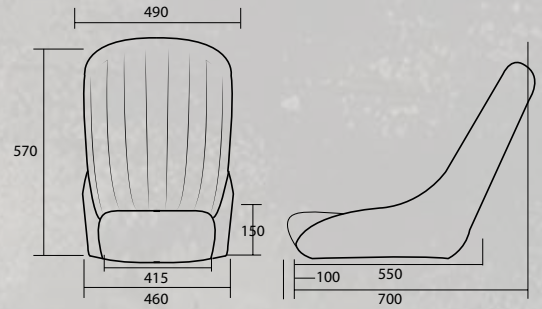

Weight 6.3kg +/- 750 grams

ROADSTER XL/XL+

- Classic/period fixed back sports seat
- Traditional styling with modern construction
- Tubular steel frame with base suspension diaphragm
- Wider hip area for increased comfort
- Heavy duty standard vinyl upholstery in black or grey
- Extensive fabric, vinyl and leather Signature options

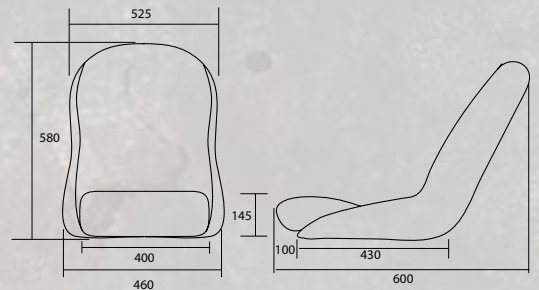

Weight 7.4kg +/- 750 grams

ROADSTER 7

- Bespoke fixed back sports seat for "7" styled vehicles
- Tubular steel frame with base suspension diaphragm
- Compact dimensions to suit narrow width cockpits
- Optimised geometry to maximise space in most "7" styled vehicles
- Meets latest IVA standards
- Integrated head restraint
- Heavy duty standard vinyl upholstery in black or grey

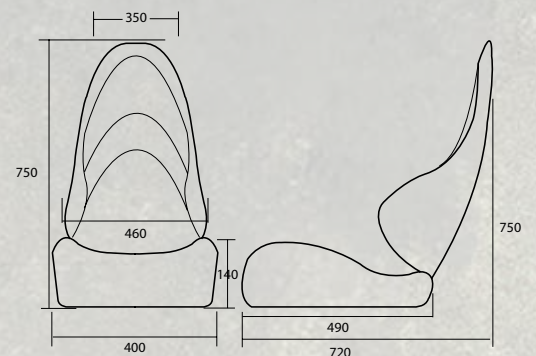

Weight 7kg +/- 750 grams

FIA HISTORIC

- Classically styled narrow FIA competition seat
- FIA homologated to 8855-1999
- 5/6 point harness facility
- Compact dimensions for narrow cockpits
- One piece heavy duty weather restraint vinyl cover
- Extensive fabric, vinyl and leather Signature options

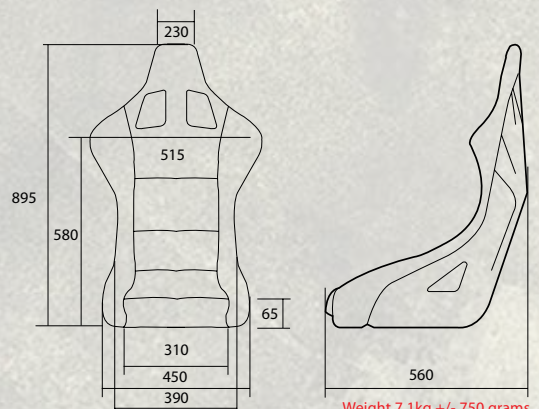

Weight 7.1kg +/- 750 grams



COBRA®

Cobra Seats Limited
Units D1 & D2, Halesfield 23
Telford TF7 4NY, England
Tel: +44 (0) 1952 684020
Fax: +44 (0) 1952 581772
E-mail: info@cobraseats.com

www.cobraseats.com

PROUDLY MADE IN GREAT BRITAIN 

